

PRODUCT CARD HEC 1.0 WITH COVER CABLE



Producer:

HeatQ Technology Sp. z o.o.

80-017 Gdańsk Trakt Św. Wojciecha 223/225

Tel.: +48 585 805 104/+48 691 209 888

www.heatq.com e-mail: biuro@heatq.com

HEATQ
— TECHNOLOGY

INTENDED USE

Electric heating element HEC with microprocessor thermostat designed to be mounted in the bathroom and for decorative radiators. The towel warmer equipped with an electric heating element can serve as an electric dryer or hybrid combining to the electric dryer and standard radiator connected to the central heating.

TYPES OF CONNECTION

- Cover cable

COLOURS OF THERMOSTATS

- Chrome, White, Black, Silver

TECHNICAL PARAMETERS

- Nominal voltage: 230V, 50Hz or 110V, 60 Hz
- Insulation class: Class I or II
- Ingress protection class: IPX4 (ZONE 2 i 3)
- Power: 120W, 200W, 300W, 400W, 500W, 600W, 800W, 1000W, 1200W

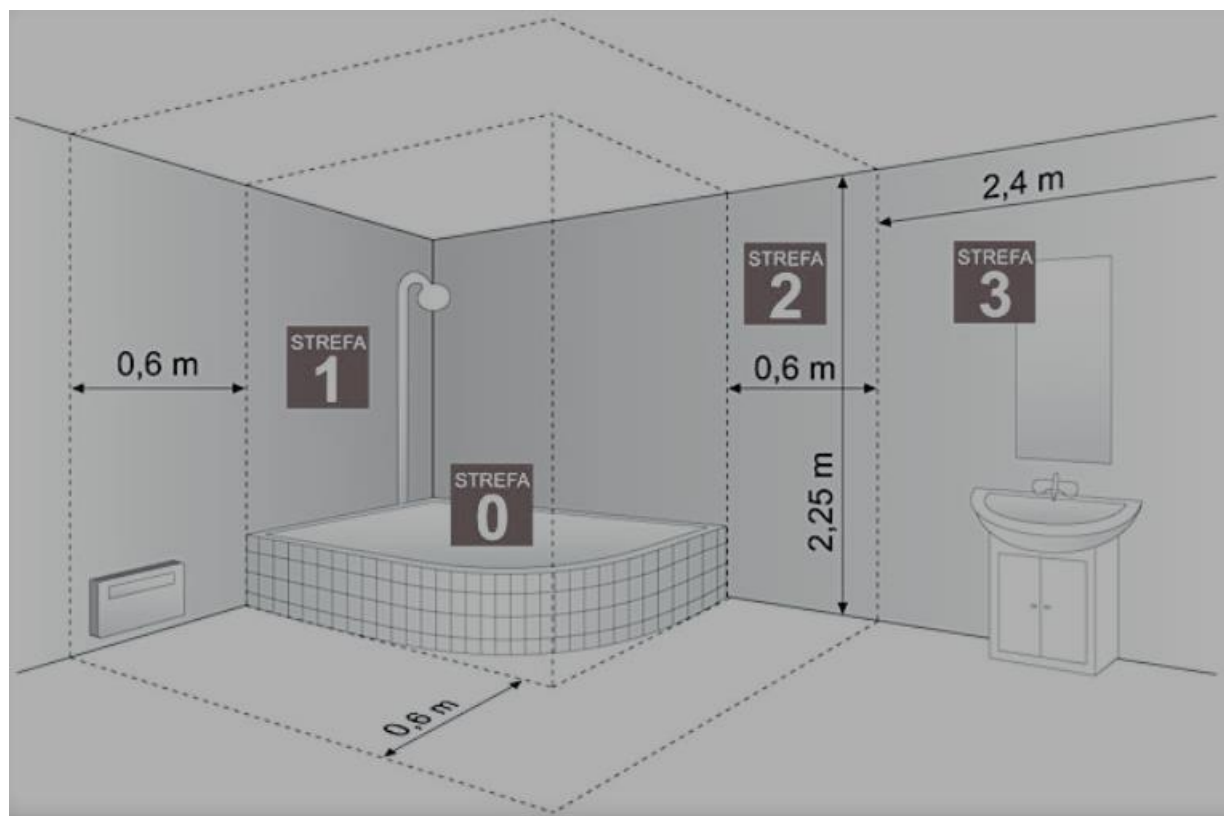

Source: NORM PN-EN 60529:2003

DIMENSION AND WEIGHT

Power	Weight	Lenght "l"	Lenght "L"
120W	0,40kg	310 mm	377mm
200W	0,39kg	270mm	327mm
300W	0,40kg	295mm	362mm
400W	0,41kg	330mm	397mm
500W	0,42kg	345mm	412mm
600W	0,42kg	360mm	427mm
800W	0,45kg	470mm	537mm
1000W	0,48kg	560mm	627mm
1200W	0,49kg	565 mm	637mm

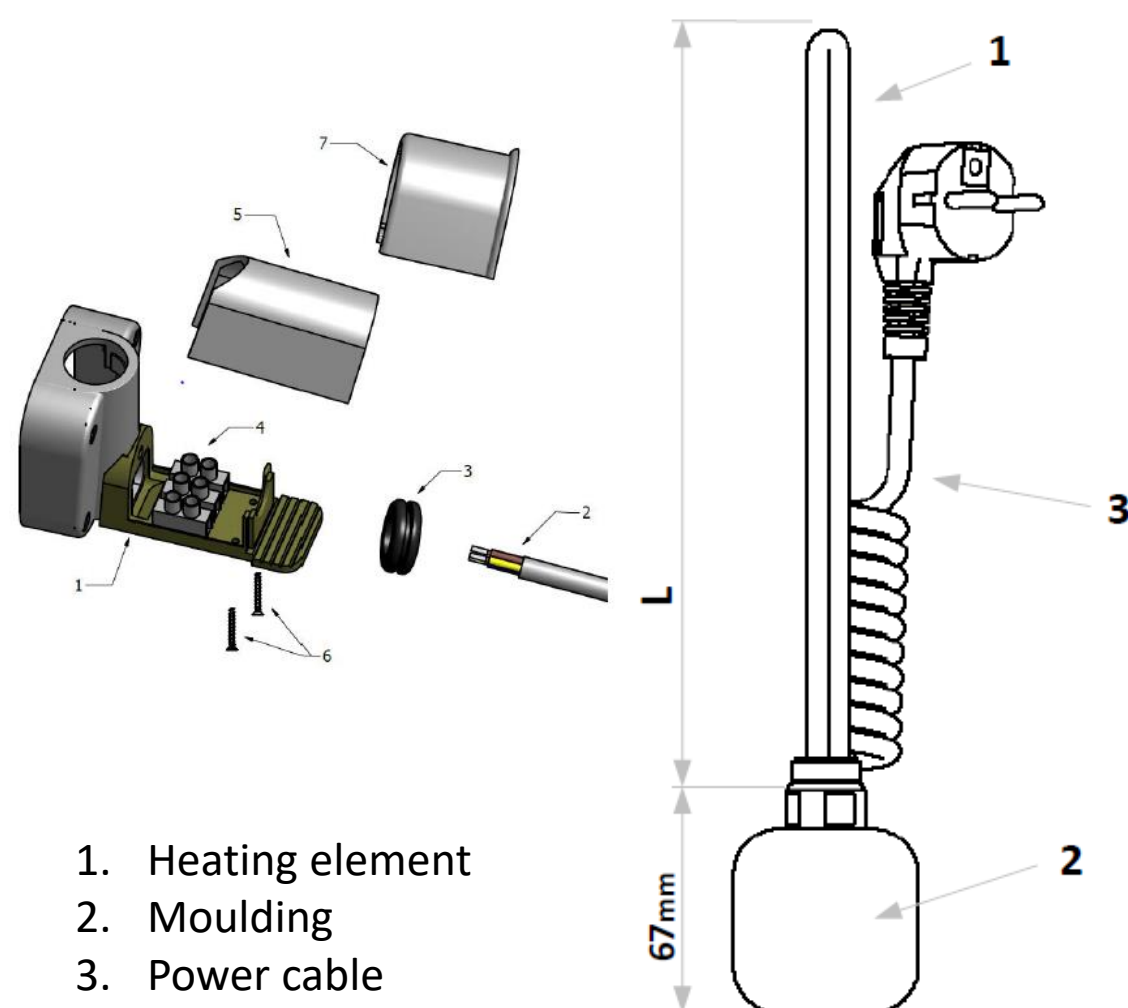

1. Heating element
2. Moulding
3. Power cable

HEC1.0 - hidden cable

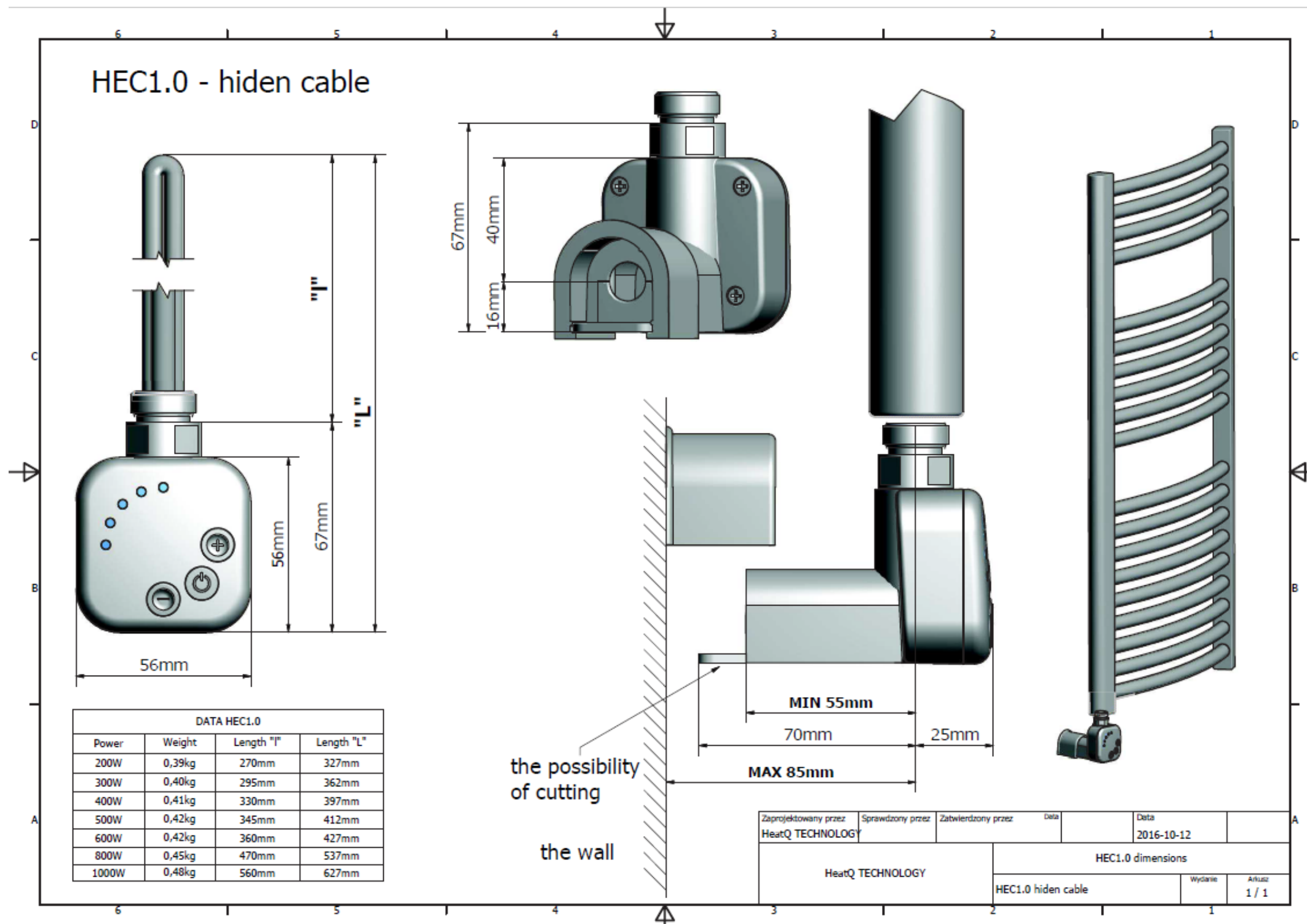

- > Higher temperature
- > TIMER TURBO – after 2h working in temperature 60°C the heater will return to the previous settings

ON/OFF

- > Lower temperature
- > TIMER START/STOP – after 2h working in temperature 60°C the heater will automatically switched off



FUNCTIONALITY

- 4 range of temperature regulation from 30°C to 60°
- dryer mode
- timer „2 h back” – after 2 h heater will return to the factory settings
- timer „2 h off” – after 2 h heater will automatically switched off
- two – level overheating protection
- ultra-low-power mode
- ANTIFREEZE mode
- intelligent technology of working system - microprocessor control
- intelligent technology of working system - visualisation in LED technology
- possibility of rotates controller from 0° to 330°.

INDEX									
Produkt	Name	Logo	Type of connection				Colours of thermostats	Power	Package
P - Product	HE1 – ELECTRIC HEATING ELEMENTS HEC 1.0	HQ - HeatQ	SCW	spiral	plug	white	WX - white	22 - 120W	B - carton
			SCB	spiral	plug	black	BX - black	02 - 200W	O - eko decorative packaging
			SCS	spiral	plug	silver	CX - chrome	03 - 300W	
			PCW	straight	plug	white	SX - silver	04 - 400W	
			PCB	straight	plug	black	BO – black matt	06 - 600W	
			SXW	spiral	without plug	white		08 - 800W	
			SXB	spiral	without plug	black		10 - 1000W	
			SXS	spiral	without plug	silver		0C - 1200W	
			PXW	straight	without plug	white			
			PXB	straight	without plug	black			
			PXS	straight	without plug	silver			
			HID	cover					

Index example: PHE1HQHIDCX03B

P – PRODUCT

HE1 – ELECTRIC HEATING ELEMENTS HEC 1.0

HQ – LOGO HEATQ

HID – COVER

CX – COLOUR OF THERMOSTAT CHROME

03 – POWER 300 W

B – CARTON

Date: 02.03.2020

Elaborate by: Natalia Woźniak

Producer:

HeatQ Technology Sp. z o.o.

80-017 Gdańsk Trakt Św. Wojciecha 223/225

Tel.: +48 585 805 104/+48 691 209 888

www.heatq.com e-mail: biuro@heatq.com

HEATQ
— TECHNOLOGY