

PRODUCT CARD NEX APP WITH SPIRAL AND STRAIGHT CABLE

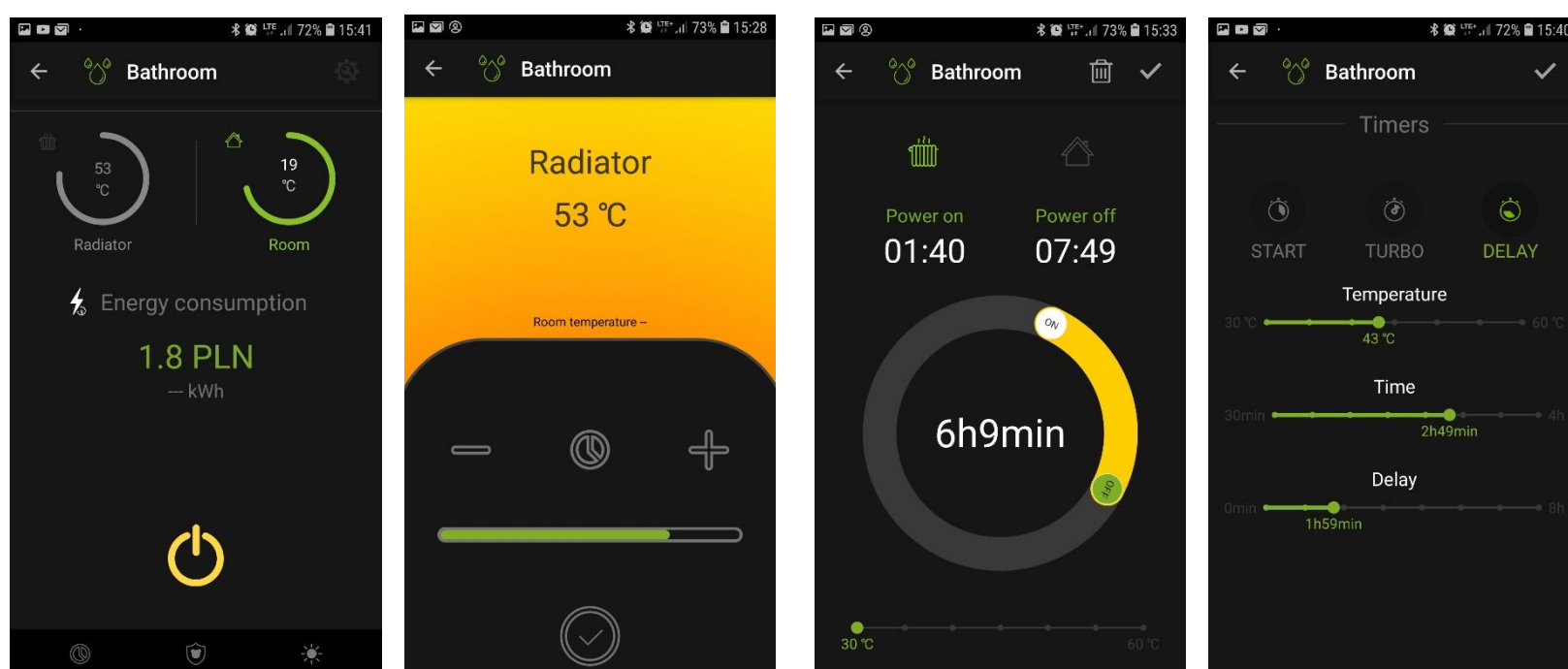

Producer:

HeatQ Technology Sp. z o.o.

80-017 Gdańsk Trakt Św. Wojciecha 223/225

Tel.: +48 585 805 104/+48 691 209 888

www.heatq.com e-mail: biuro@heatq.com



HEATO
— TECHNOLOGY

INTENDED USE

Electric heating element with controller, radio communication 868 MHz and Bluetooth module. Radiator equipped with the electric heating element with NEX thermostat performs function of electric dryer, space heater or hybrid combining to the electric dryer and standard radiator connected to the central heating. Due to intuitive operation the device programming is simply and user-friendly, including the operation of mobile application NEX APP available on App Store and Google Play.

TYPES OF CONNECTION

- spiral cable
- straight cable

COLOURS OF THERMOSTATS:

- chrome, white, black, black mat, silver

TECHNICAL PARAMETERS

- nominal voltage: option 1: 230V, 50Hz;
option 2: 110V, 60 Hz
- insulation class: option 1: Class I; option 2: Class II
- ingress protection class: IPX5 (ZONE 2 i 3)
- power: 120W, 200W, 300W, 400W, 500W, 600W, 800W, 1000W, 1200W

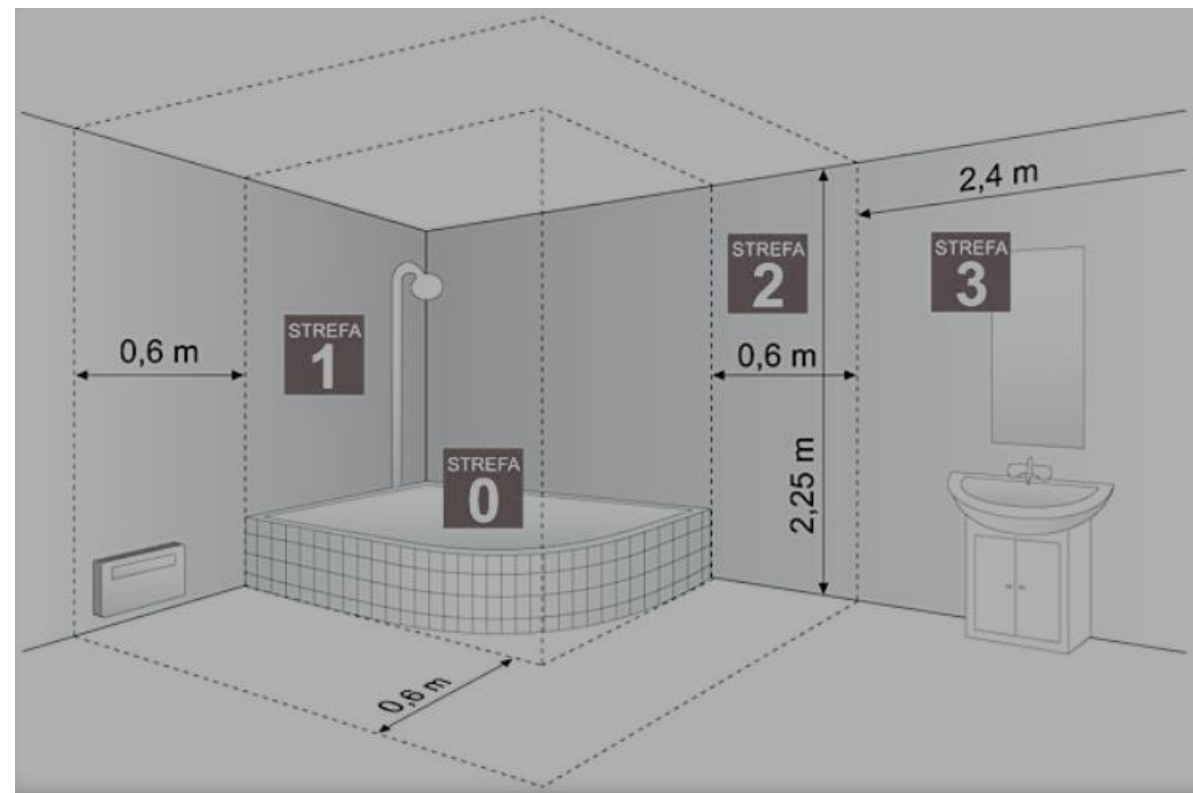

Source: NORM PN-EN 60529:2003

DIMENSION AND WEIGHT			
Power	Weight	Lenght "l"	Lenght "L"
120W	0,40kg	310 mm	377mm
200W	0,39kg	270mm	327mm
300W	0,40kg	295mm	362mm
400W	0,41kg	330mm	397mm
500W	0,42kg	345mm	412mm
600W	0,42kg	360mm	427mm
800W	0,45kg	470mm	537mm
1000W	0,48kg	560mm	627mm
1200W	0,49kg	565 mm	637mm

1. Heating element
2. Controller housing
3. Power cable

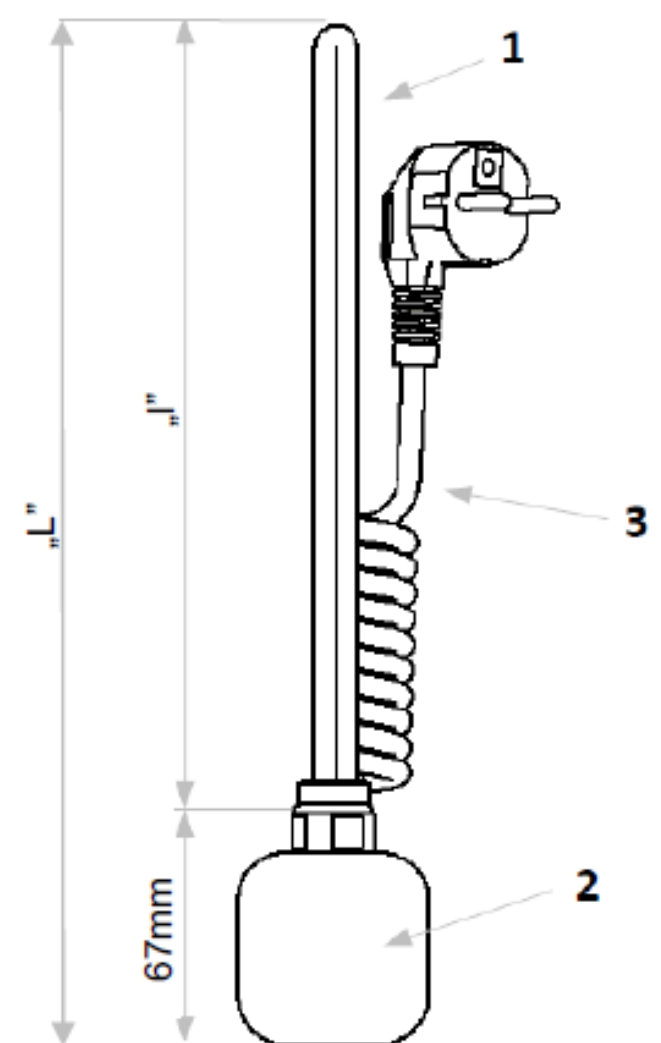

NEX1.0 - with straight/spiral cable

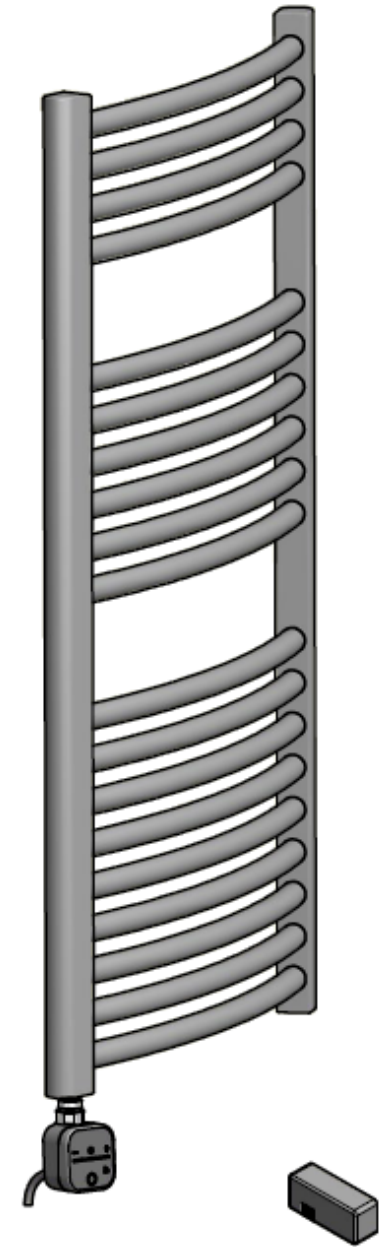
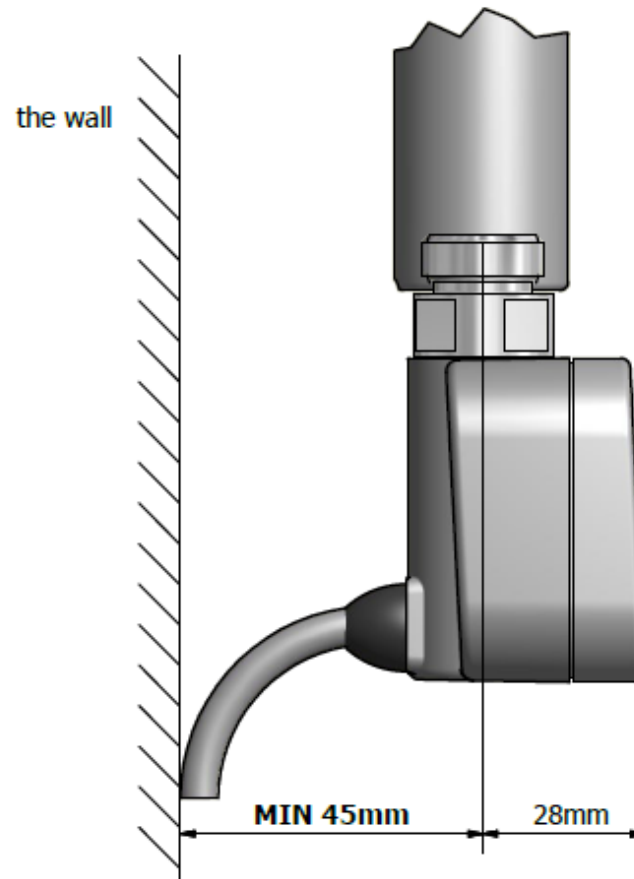
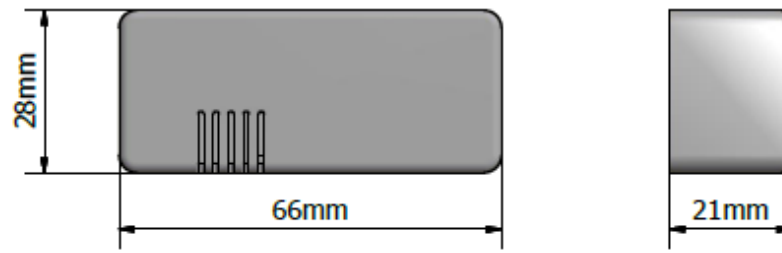
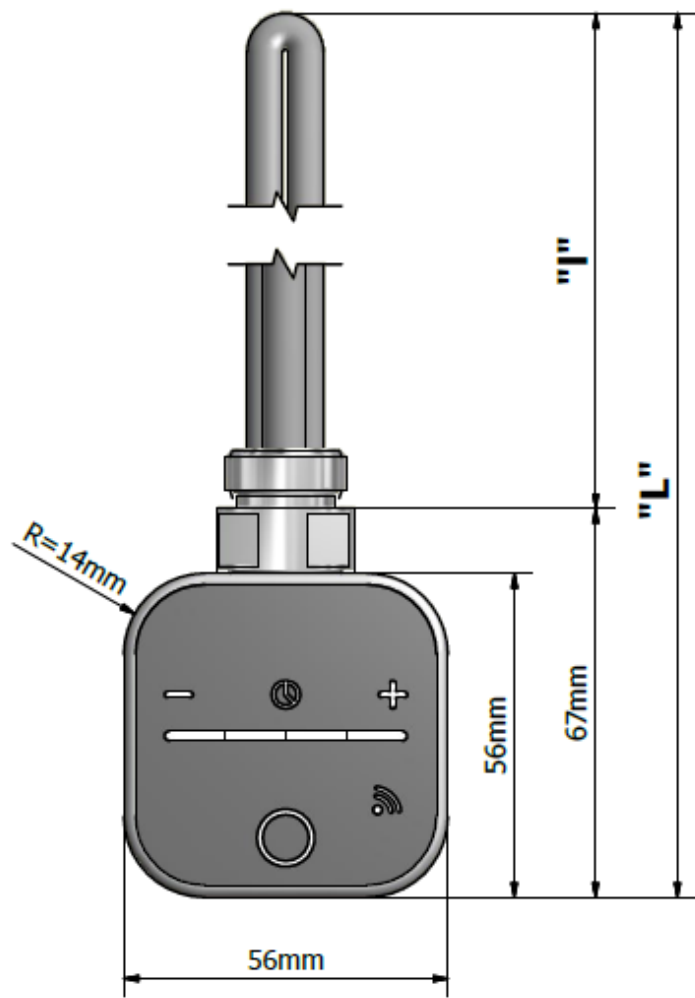

DATA NEX1.0			
Power	Weight	Length "l"	Length "L"
200W	0,39kg	270mm	327mm
300W	0,40kg	295mm	362mm
400W	0,41kg	330mm	397mm
500W	0,42kg	345mm	412mm
600W	0,42kg	360mm	427mm
800W	0,45kg	470mm	537mm
1000W	0,48kg	560mm	627mm

Zaprojektowany przez HeatQ TECHNOLOGY Sp. z o.o.	Sprawdzony przez	Zatwierdzony przez	Data	Data	
				2018-11-29	
HeatQ TECHNOLOGY Sp. z o.o.			NEX1.0 dimensions		
			HQT_NEX- cable_dimensions_01	Wydanie	Arkusze
					1 / 1

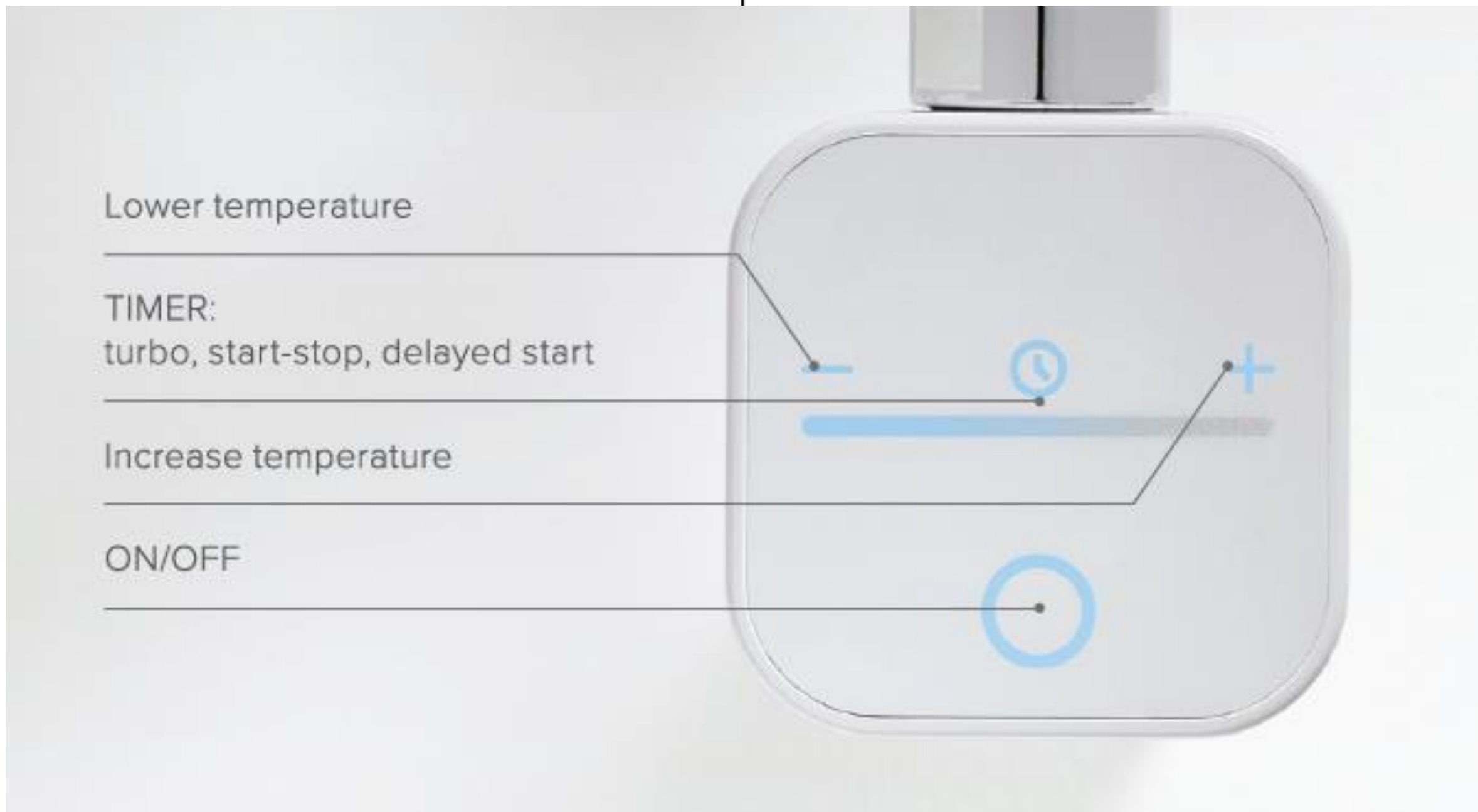

FUNCTIONALITY OF THE NEX APP

- remote control via the application on a mobile device
- daily and weekly work schedule
- energy consumption meter
- measuring the room temperature/ stopping the heating function for the time the window/door is open
- timers: TURBO, START-STOP, DELAYED START
- 4-stage temperature regulation in the range of 30 ° – 60 ° C
- controller rotation in the range of 0° – 330°
- ANTIFREEZE function
- two-level overheating protection
- additional protection against working when "dry"
- low power consumption in standby mode (Ultra-Low-Power)
- dryer function
- intelligent work control – microprocessor control
- visualization in colorful LED technology
- free application NEX APP on App Store and Google Play

INDEX

Product	Type of connection	Colours	Power	Package	Optional equipment
PNX2 – ELECTRIC HEATING ELEMENTS NEX APP	PC – straight cable with the plug	WX - white	22 - 120W	B – carton without the print	T- tee
	PX – straight cable without the plug	BX - black	02 - 200W	O – carton with the print	ST – additional temperature sensor
	SC – spiral cable	BO – black mat	03 - 300W	R - foil	OW – open window/door sensor
		SX - silver	04 - 400W		~ - free application to download on Google Play and App Store
		CX - chrome	06 - 600W		
			08 - 800W		
			10 - 1000W		
			0C - 1200W		

Example of index: PNX2SCCX03B

PNX2 – ELECTRIC HEATING ELEMENT NEX APP

SC – MASKING CABLE

CX – COLOR OF THERMOSTAT CHROME

03 – POWER 300 W

B – CARTON WITHOUT THE PRINT

Producer:

HeatQ Technology Sp. z o.o.

80-017 Gdańsk, Trakt Św. Wojciecha 223/225

Tel.: +48 585 805 104/+48 691 209 888

www.heatq.com e-mail: biuro@heatq.com

Date: 29.10.2020 r.

Prepared by: Urszula Wasielewska

HEATQ
— TECHNOLOGY